

Power Clamps

Steel, Pneumatic

SPECIFICATION

Type

Type **BL**: Clamping arm horizontal
Steel C45

- Chemically nickel plated **NC**
- Anti-stick coating
Polytetrafluorethylene (PTFE), green **FG**

Max. pressure 10 bar

INFORMATION

The maximum clamping moment of the power clamps GN 864 is reached once the clamping arm is at the end of its stroke. For this reason the working stroke should be completed as closely as possible to the stroke end.

The type FG is equipped with an anti-stick coating of polytetrafluorethylene (PTFE) for protection against welding spray and corrosion. With protective covers GN 864.1 (see page) the tensioning mechanism can be additionally protected against penetrating dirt.

- Information for pneumatic fastening clamps (see page 1632)

ACCESSORY

- Protective covers GN 864.1 (see page)

TECHNICAL INFORMATION

- ISO-Fundamental Tolerances (see page A21)
- Plastic Characteristics (see page A2)
- List of pneumatic clamps (see page)

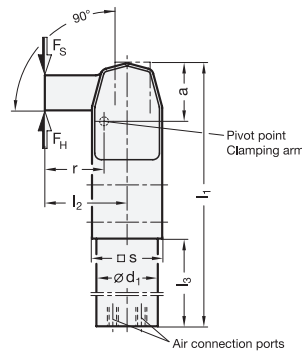

Operating principle

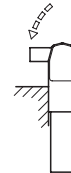

View from below (Air connection ports)

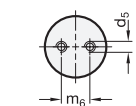

Top view

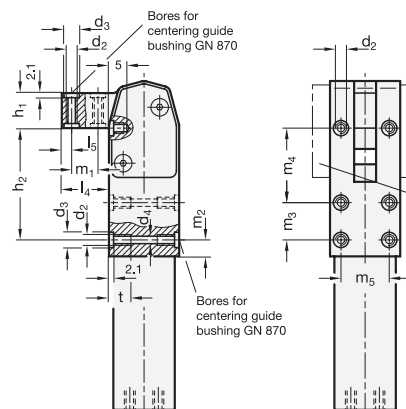
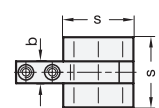

* Complete with type index of the power clamps

NC Chemically nickel plated **FG** Polytetrafluorethylene (PTFE), green

GN 864

Description	Size	max. clamping moment in Nm at 6 bar	F _S in N	F _H in N	a	b -0.2	d ₁ h8	d ₂	d ₃ H8	d ₄	d ₅	h ₁	h ₂	h ₃	h ₄	h ₅	l -0.5	l ₂	l ₃	l ₄	l ₅	m ₁ ±0.01	m ₂	m ₃ ±0.01	m ₄	m ₅ ±0.01	m ₆	r	s	t		
GN 864-20-BL-*	20	60	2220	7030	27	10	28	M 5	7	4.2	M 5	16	51	150	37.5	70	21.5	4.5	12	7.5	17	34	22	13	27	32	13	640				
GN 864-32-BL-*	32	150	4110	12876	36.5	12	40	M 6	9	5	G 1/8	21	75.5	206	52	91	31	6	18	10	25	51	30	22	36.5	42	15	1500				
GN 864-40-BL-*	40	300	6740	16943	44.5	16	50	M 8	11	6.8	G 1/8	26	91.5	244	63	104	37	7.5	22	13	30	62	37	25	44.5	52	18	2820				
GN 864-50-BL-*	50	475	9000	22666	52.5	18	60	M 10	13	8.5	G 1/8	31	114	279	74	110.5	43	8	27	12	47	71.5	44	35	52.5	62	21	3800				

Weight type NC

Installation examples

Holder for clamping bolts GN 867

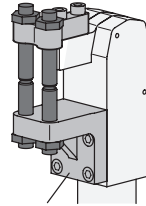
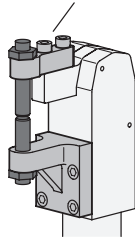

Static holder for clamping bolts GN 867.1

Holder for clamping jaws GN 868

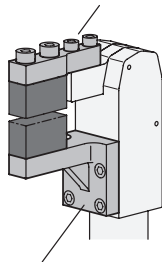

Clamping jaws GN 872

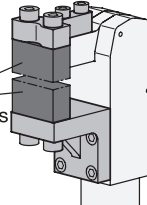

Holder for clamping jaws GN 868.1

Principle of operation

